

INDUCTIVE PROXIMITY SENSORS

- SENSE FERROUS & NON-FERROUS METAL OBJECTS TO "ZERO SPEED"
- 2-WIRE CURRENT SOURCE (NAMUR) & 3-WIRE NPN TRUE OPEN COLLECTOR OUTPUTS
- 5 SIZES & 3 SENSING DISTANCES FOR APPLICATION VERSATILITY
- L.E.D. TARGET INDICATOR (PSA 2B, 6B, 7B, & 8B)

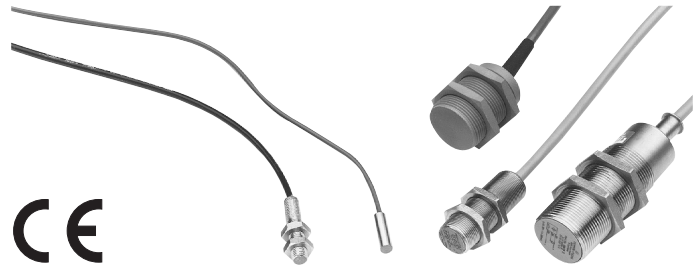

DESCRIPTION & OPERATION

Inductive Proximity Sensors detect the presence of metal objects which come within range of their oscillating field and provide target detection to "zero speed". Internally, an oscillator creates a high frequency electromagnetic field (RF) which is radiated from the coil and out from the sensor face (See Figure 1). When a metal object enters this field, eddy currents are induced into the object.

As the metal moves closer to the sensor, these eddy currents increase and result in an absorption of energy from the coil which dampens the oscillator amplitude until it finally stops.

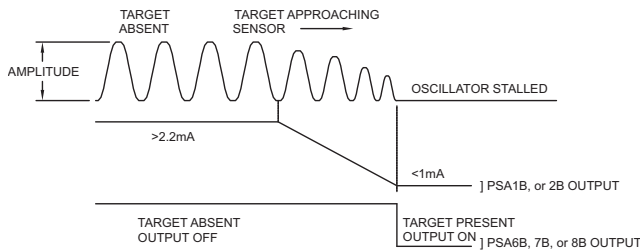
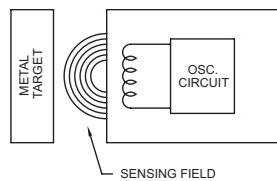

Figure 1

MODELS PSA-1B & 2B

The 2-wire Models PSA-1B and 2B contain only the coil and oscillator circuit (See Figure 2). With no metal object being sensed, the circuit oscillates and draws greater than 2.2 mA of supply current. As a metal object of sufficient size is brought into the sensing field, the oscillator amplitude dampens and finally stops, resulting in less than 1 mA of circuit current being drawn. This greater than 2.2 mA to less than 1 mA change in circuit current between oscillating and non-oscillating conditions is converted into a usable voltage signal (V_s) by placing a resistor (R_s) in series with the sensor leads.

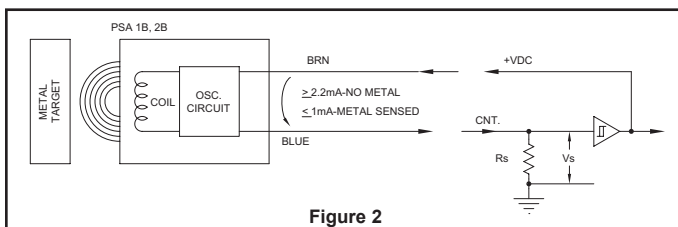

Figure 2

PSA-1B & PSA-2B SPECIFICATIONS

	PSA-1B	PSA-2B
1. Power Supply:	+5 to +30 VDC	
2. Maximum Switching Frequency:	5 KHz	500 Hz
3. Output:	Less than 1 mA Target Sensed; Greater than 2.2 mA No Target.	
4. Maximum Sensing Distance:	0.059" (1.5 mm)	0.394" (10 mm)
5. Wire Color Code:	Brown = +VDC; Blue = Count	
6. Operating Temperature:	-25°C to +70°C (-13°F to +158°F)	
7. Construction:	NEMA 1, 3, 4, 6, 13, and IEC IP 67.	

DIMENSIONS In inches (mm)

PSA-1B

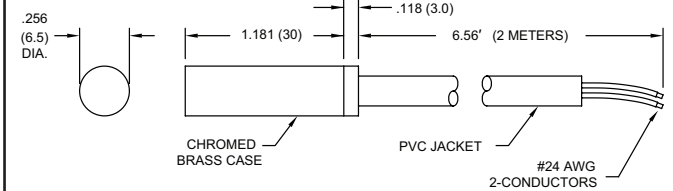

PSA-2B

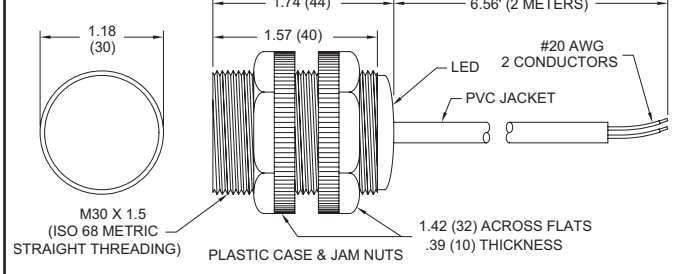

In addition to the coil and oscillator circuit, the 3-wire Models PSA-6B, 7B, and 8B each contain a Detector Circuit and NPN Transistor Output (See Figure 3). In these units, the Detector Circuit senses when the oscillator stops, and turns on the Output Transistor which controls the load. The Detector Circuit also turns on an integrally case mounted L.E.D., visually indicating when a metal object is sensed.

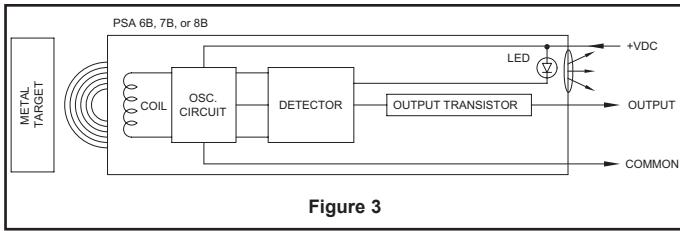

Figure 3

PSA-6B, 7B, & 8B

These Inductive Proximity Sensors have a maximum sensing distance of 0.059" (1.5 mm), 0.197" (5 mm) and 0.394" (10 mm) respectively, and operate over a wide power supply range (See Specifications Below). They are each housed in threaded metal cases and are supplied with 2 metal jam nuts for mounting. The NPN transistor outputs are true open collector and are compatible with most RLC counter and rate input circuits. Maximum sensing frequencies are ≤ 3 KHz, 1 KHz, and 500 Hz respectively. In addition, the outputs are overload and short circuit protected. These sensors are shielded for flush mounting in metal applications.

PSA-6B, 7B, & 8B SPECIFICATIONS

	PSA-6B	PSA-7B	PSA-8B
1. Power Supply:	+10 to +30 VDC @ 10 mA max. REVERSE POLARITY PROTECTION		
2. Maximum Switching Frequency:	≤ 3 KHz	1 KHz	500 Hz
3. Output:	NPN Open Collector Output, Overload and Short Circuit protected. $V_{SAT} = 1.8 V @ 150 mA \text{ max. load}$ $V_{SAT} = 1.8 V @ 200 mA \text{ max. load}$		
4. Maximum Sensing Distance:	0.059" (1.5 mm)	0.197" (5 mm)	0.394" (10 mm)
5. Wire Color Code:	Brown = +VDC; Blue = Common; Black = Output		
6. Operating Temperature:	-25°C to +70°C (-13°F to +158°F)		
7. Construction:	NEMA 1, 3, 4, 6, 13 and IEC IP 67		

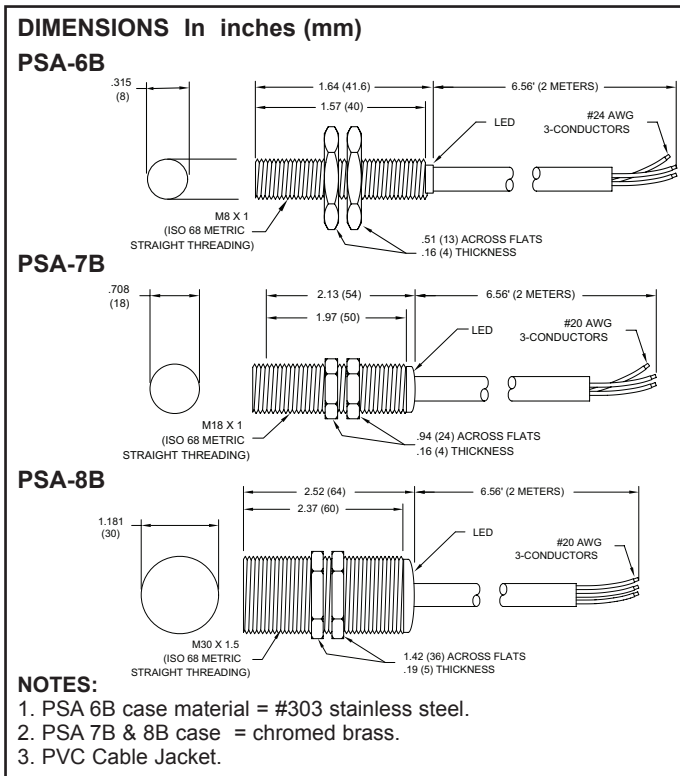

SELECTION & APPLICATION OF PROXIMITY SENSORS

Selection of the proper proximity sensor depends on the size, material, and spacing of the target being sensed and the sensing distance that can be maintained. The maximum sensing distance is defined as the distance in which the sensor is just close enough to detect a ferrous target whose diameter is equal to or greater than the sensor diameter. In actual application, the sensing distance should be between 50 to 80% of the maximum sensing range to assure reliable detection. For target sizes smaller than the sensor diameter, the maximum sensing distance can be estimated from the curve (See Figure 4). A further reduction factor must also be applied if the target material is non-ferrous metal (See Figure 5). Ideally, spacing between adjacent targets should be at least one sensor diameter so that the first target completely leaves the sensors field before the next target appears. Individual targets can still be resolved as separate objects if this spacing is reduced to 70 or 75% of the sensor diameter, however, this can introduce a minimum limit on sensing distance that makes adjustment more critical. All Proximity sensors are internally shielded which allows the sensor face to be flush mounted in metal applications without reducing sensing distance. In applications where proximity sensors must be placed next to each other, a distance of at least 1 sensor diameter should separate sensors to eliminate any frequency interference (See Figure 6).

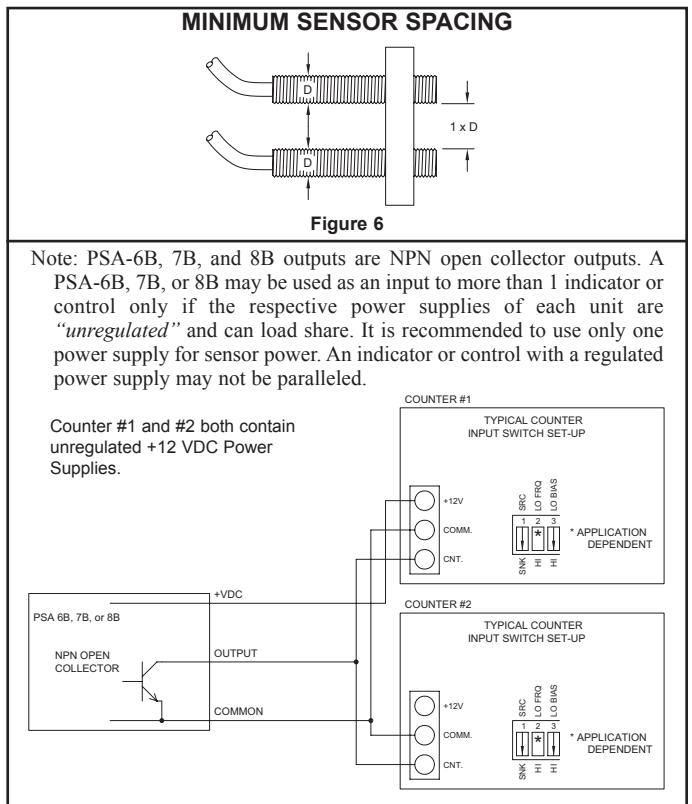
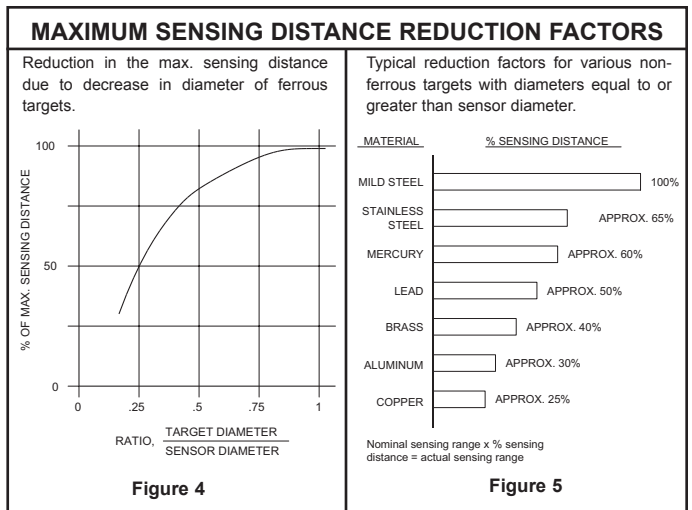

TYPICAL HOOK-UPS

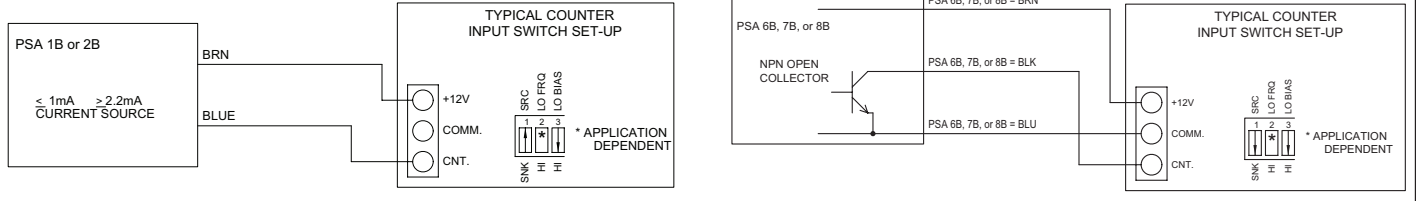

APPLICATION SELECTION CHART

	PSA-1B	PSA-2B	PSA-6B	PSA-7B	PSA-8B
MAX. SENSING DISTANCE	0.059" (1.5 mm)	0.394" (10 mm)	0.059" (1.5 mm)	0.197" (5 mm)	0.394" (10 mm)
MAX. SWITCHING FREQ.	5 KHz	500 Hz	≤ 3 KHz	1 KHz	500 Hz
POWER SUPPLY	5-30 VDC	5-30 VDC	10-30 VDC	10-30 VDC	10-30 VDC
OUTPUT	<1 mA> 2.2 mA	<1 mA> 2.2 mA	NPN Open Collector Transistor		
L.E.D. TARGET INDICATOR	No	Yes	Yes	Yes	Yes

MODELS MB4B & 5B MOUNTING BRACKETS

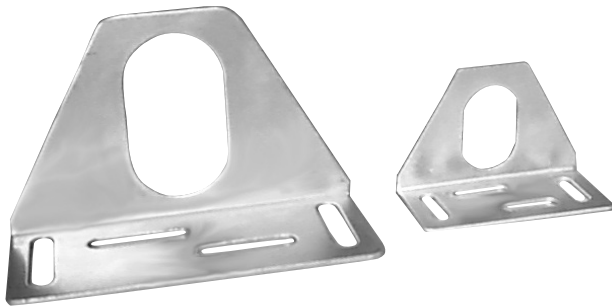

DIMENSIONS

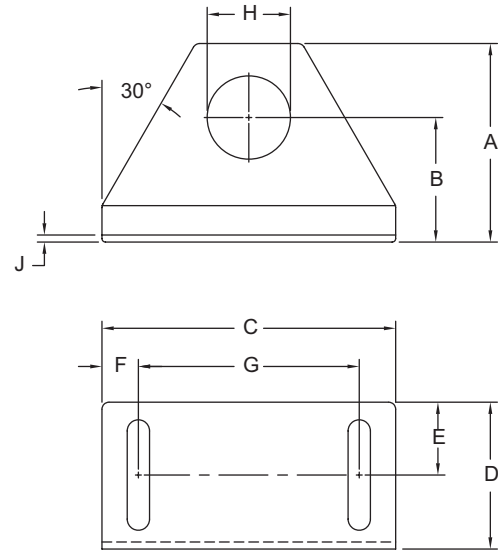

The Models MB4B and 5B are stainless steel right angle mounting brackets, designed to provide easy mounting and adjustment of PSA-7B and 8B respectively, using the 2 hex jam nuts provided with each sensor.

DIMENSIONS In inches (mm)

BRACKET MODEL NO.	SENSOR MODEL	DIMENSIONS									
		A	B	C	D	E	F	G	H	J	SLOT
MB4B	PSA7B	1.63 (41.5)	1.00 (25.4)	2.5 (63.5)	1.25 (31.8)	0.62 (15.7)	0.31 (7.9)	1.88 (47.8)	0.75 (19.1)	0.06 (1.5)	0.22 X 0.75 (5.6 X 19.1)
MB5B	PSA8B	2.62 (66.5)	1.75 (44.5)	4.25 (108.0)	1.75 (44.5)	0.88 (22.4)	0.37 (9.5)	3.50 (88.9)	1.19 (30.2)	0.07 (1.8)	0.28 X 1.25 (7.1 X 31.8)

ORDERING INFORMATION

MODEL NO.	DESCRIPTION	PART NUMBER
PSA1B	2-Wire Cylindrical Proximity Sensor	PSA1B000
PSA2B	2-Wire, 30 mm Threaded Proximity Sensor	PSA2B000
PSA6B	8mm Threaded Proximity Sensor	PSA6B000
PSA7B	18mm Threaded Proximity Sensor	PSA7B000
PSA8B	30mm Threaded Proximity Sensor	PSA8B000
MB4B	Mounting Bracket for PSA7B	MB4B0000
MB5B	Mounting Bracket for PSA8B	MB5B0000



Do not dispose of unit in trash - Recycle

